

THE

General Radio EXPERIMENTER



VOLUME XXVIII No. 6

NOVEMBER, 1953

Copyright, 1953, General Radio Company, Cambridge, Mass., U. S. A.

ELECTRICAL MEASUREMENTS AND THEIR INDUSTRIAL APPLICATIONS



A LABORATORY AMPLIFIER FOR AUDIO AND ULTRASONIC FREQUENCIES

The TYPE 1206-B Unit Amplifier, newest member of the General Radio family of Unit Instruments,¹ is a high-quality amplifier, designed for general laboratory use. Its maximum output power of 3 watts is adequate for driving low-power transducers, and its wide frequency range (up to 250 kc) makes it useful as an amplifier for the output of such oscillators as the TYPE 1301-A and the TYPE 1302-A or for pulses with rise times as short as one microsecond. In conjunction with a pair of earphones, it has sufficient gain for use as a null detector in bridge measurements.

The General Radio unit construction makes possible a low price and a small compact assembly, which can be bolted to the TYPE 1203-A Unit Power Supply to form a single unit.

Circuit Details

This amplifier takes advantage of the desirable characteristics of the single-ended push-pull circuit to obtain low distortion over a wide frequency range.

¹For other Unit Instruments, see the *General Radio Experimenter* for May, 1950; July, 1951; February, 1952; February, 1953, and September, 1953.

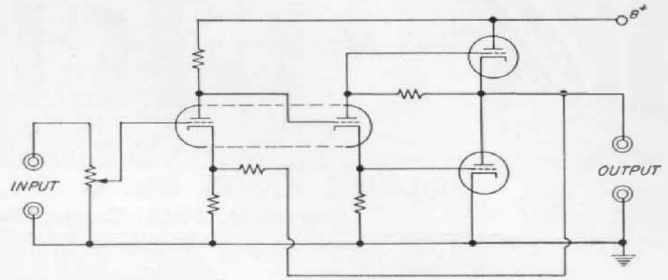

Figure 1. Elementary schematic circuit diagram of the Type 1206-B Unit Amplifier.

This type of circuit has been discussed in previous articles^{2,3} and is shown in basic form in Figure 1. Note that the upper output tube is driven from grid to cathode, not grid to ground, and that the a-c currents of both tubes add in the load, while the grid voltages are of opposite phase. Therefore it has true push-pull operation and single-ended output without the use of an output transformer. In a conventional push-pull circuit, the frequency range is severely limited by the output transformer.

The unit amplifier was designed for use with the TYPE 1203-A Unit Power

²A. P. G. Peterson, "A New Push-Pull Amplifier Circuit," *General Radio Experimenter*, October, 1951, pp. 1-7.

³A. P. G. Peterson and D. B. Sinclair, "A Single-Ended Push-Pull Amplifier," *Proc. I.R.E.*, January, 1952, pp. 7-11.

ALSO IN THIS ISSUE

	Page
OSCILLATOR CONSIDERATIONS.....	6
ELECTROLYTIC CAPACITOR TESTING AT 120 CYCLES.....	8

COVER PHOTO

In the production of textile yarns, the speeds of the processing machinery are extremely important. Constant speed assures uniform quality and fewer defects in the cloth woven from the yarn, while the maintenance of rated speeds is necessary for efficient production.

The stroboscopic method of speed measurement is widely used in textile plants, because there is no mechanical contact between machine and tachometer, so that the speed of the machine is not affected. In spinning and twisting operations, a complete frame of spindles can be checked quickly for proper speed and, at the same time, defects in the operation of the machine can be spotted by means of the slow-motion effect.

This photograph shows the General Radio Strobotac® being used to measure the speeds of spindles on an Atwood twister and to observe the shape of the yarn balloons.



Figure 2. Panel view of the amplifier.

Supply, whose output necessarily limits the maximum output power of the amplifier and the choice of tube types. Of the available tube types that could be operated from the power supply, a pair of triode-connected 6W6-GT's gave the best results.

A 12AX7 miniature twin triode is used in the input stage and phase inverter since it combines the economy of

a single envelope with the desirable features of high gain and low cathode-heater power. It will be noted from Figure 3 that the phase-inverter plate supply is taken from B+ through a resistor to enable this stage to handle larger signals. A capacitor connects the phase-inverter plate resistor to the output, so that for a-c signals the circuit is equivalent to that of Figure 1. The

Figure 3. Complete circuit diagram.

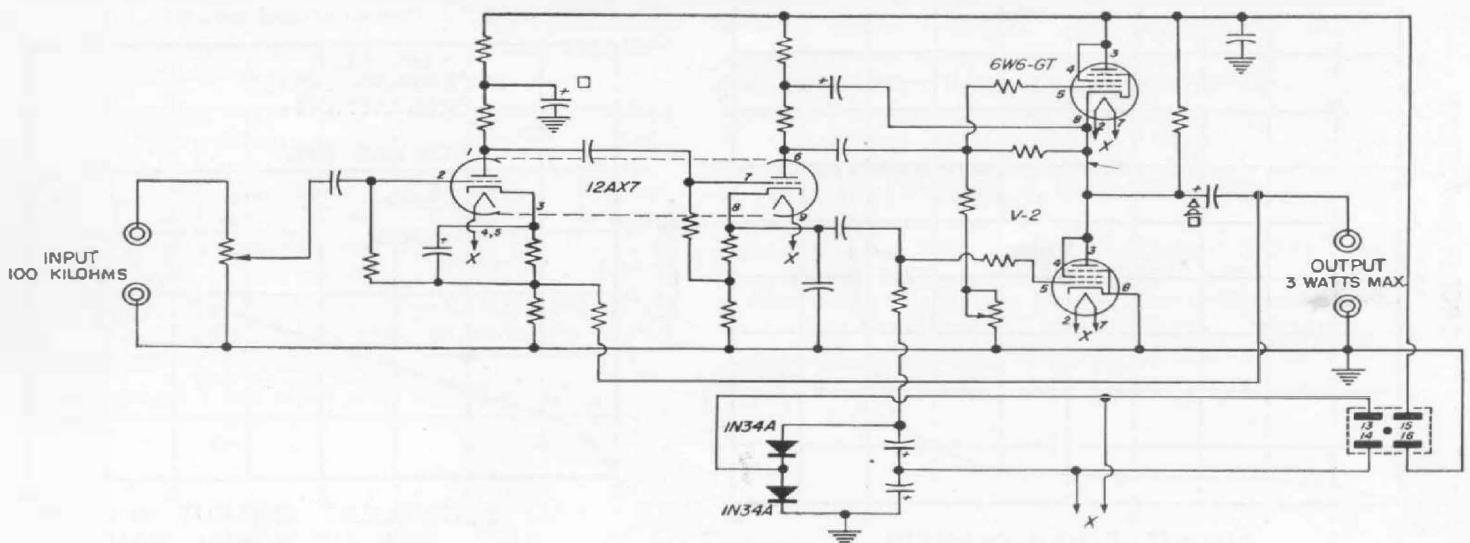

first stage has a gain of about 50, and the phase inverter and output stage have an over-all gain of about 3.5 when loaded with 600 ohms. Feedback reduces this gain by a factor of 4. Full output is obtained with an input signal of slightly less than 1 volt. With no load, the gain is approximately 50.

OPERATING CHARACTERISTICS

Output power vs. load for a total distortion of 1% is shown in Figure 4 for a typical instrument. It can be seen that the optimum load is slightly more than 600 ohms. The output impedance would be about 400 ohms with no feedback, and it is 100 ohms with feedback.

Figure 5 shows harmonic distortion as a function of output power for a typical instrument at 1 kc. At 20 cycles and 40 kc, the distortion is slightly higher. These curves are taken with the amplifier supplied from a TYPE 1203-A Unit Power Supply operating from a line voltage of 115 volts. The voltage output for a given distortion and load is roughly proportional to the line voltage.

The intermodulation distortion in this amplifier is essentially independent of the component frequencies over the audio range. At 3-watts output, the

Figure 5. Harmonic distortion as a function of output power at a frequency of 1 kc with 115-volt line.

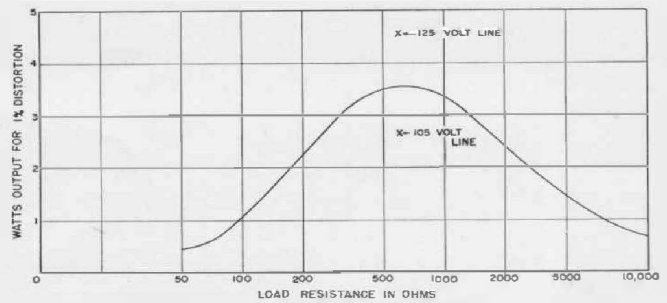
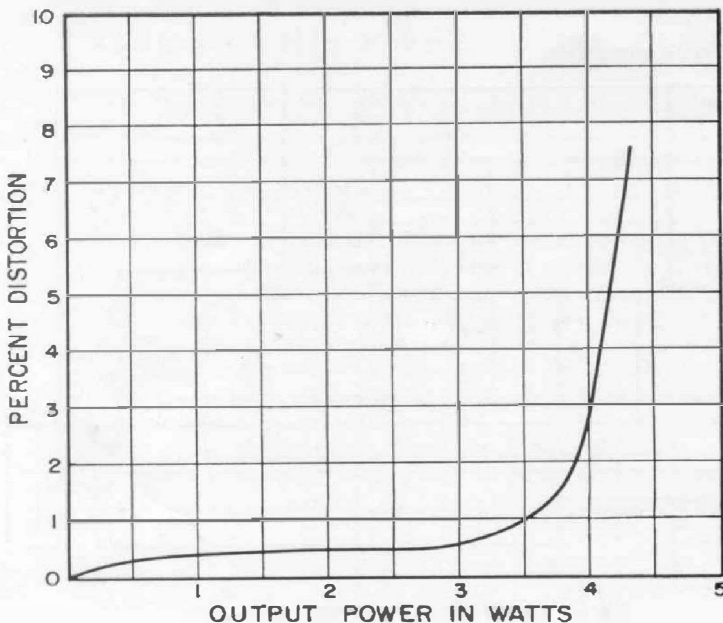

Figure 4. Output power as a function of load resistance for a total harmonic distortion of 1%, with the power supply operating from a 115-volt line. Points are also shown for 105-volt and 125-volt lines.

CCIF⁴ quadratic intermodulation distortion is about 0.25%, and the cubic is about 0.6%. The SMPTE intermodulation is shown in Figure 6 as a function of output power. Up to 3 watts, the distortion is well below the 5% intermodulation limit usually set for high-quality amplifiers.

The frequency characteristics of the amplifier are given in Figures 7 and 8 for a 600-ohm load and no load. The solid curves are the output (measured with a peak-reading voltmeter) for a constant input level. At the frequency extremes, distortion occurs owing to the relatively limited frequency response of the phase inverter. The dashed curves give the maximum output for an output waveform that is not visibly distorted on a cathode-ray oscillograph.

⁴A. P. G. Peterson, "An Audio-Frequency Signal Generator for Non-Linear Distortion Tests," *General Radio Experimenter*, August, 1950.

Figure 6. Intermodulation distortion (SMPTE method) as a function of output power.

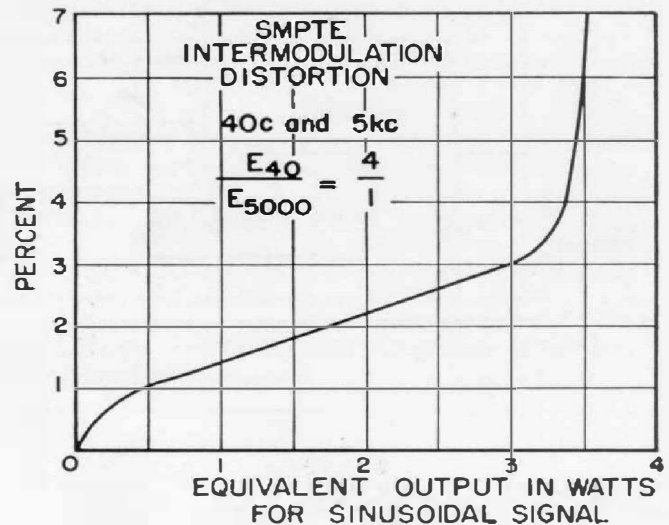

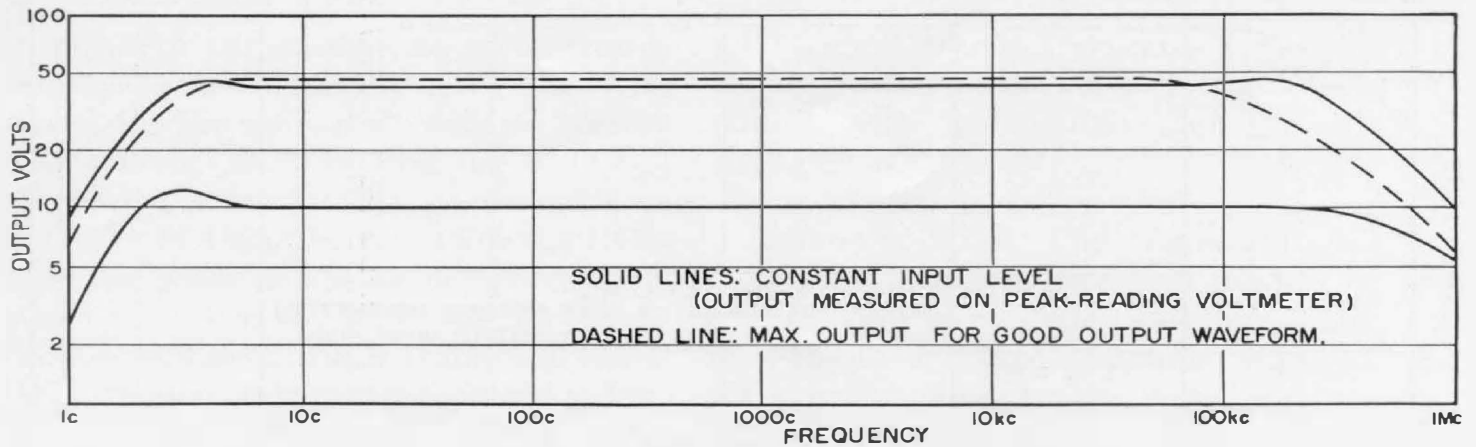

Figure 7. Output voltage vs. frequency with 600-ohm load. Solid curves are for constant input level, dashed curves for good output waveform.

USES

The TYPE 1206-B Unit Amplifier has been designed to give full output with a maximum input of one volt, corresponding to the output voltage of many electro-acoustic and electro-mechanical measuring devices. Thus it can be used to amplify their outputs to a level sufficient to operate graphic recorders. Typical examples of these devices are the TYPE 1551-A Sound-Level Meter, the TYPE 760-B Sound Analyzer, the TYPE 1550-A Octave-Band Noise Analyzer,

⁵Horatio W. Lamson, "Type 941-A Toroidal Transformer," *General Radio Experimenter*, September, 1950, pp. 5-8.

the TYPE 761-A Vibration Meter, and the TYPE 762-B Vibration Analyzer.

It is also useful in amplifying the output of the TYPE 1390-A Random-Noise Generator for audio-frequency tests.

For use with load impedances other than 600 ohms, the TYPE 941-A Toroidal Transformer⁵ is an excellent impedance matching device. With this transformer, load impedances from 37.5 ohms to 9600 ohms can be matched to the 600-ohm amplifier impedance. Frequency response covers approximately four decades.

— HENRY P. HALL

SPECIFICATIONS

Power Output: With 300-volt plate supply and 600-ohm load:

- 3 watts from 20 cycles to 50 kc.
- 1.5 watts from 10 cycles to 100 kc.
- 0.5 watt at 250 kc.

Distortion: Less than 1% harmonic distortion with 2 watts output (2% with 3 watts) into 600 ohms from 20 cycles to 40 kc.

Pulse Response:

	No Load	600Ω
Drop in 30-cycle square wave	15%	20%
Approx. Rise time:		

50 v peak-to-peak	1 μsec.	2 μsec.
100 v peak-to-peak	2 μsec.	4 μsec.
Max output, peak-to-peak magnitude	260 v	120 v

Load Impedance: 600 ohms optimum. Blocking capacitor is 100 μf. (Source impedance about 100 ohms.)

Input Voltage: Less than one volt for full power output.

Input Impedance: 100,000 ohms in parallel with 35 μf.

Frequency Response: Essentially flat from 10 cycles to 100 kc (see power output specification).

Voltage Gain: Continuously adjustable. Maximum voltage gain is 50 (34 db), with no load.

A-C Hum: Maximum a-c hum in output with TYPE 1203-A Unit Power Supply is less than 15 mv, rms.

Power Requirements: 6.3 volts, 2.7a; 300 volts, 50 ma. TYPE 1203-A Unit Power Supply is recommended.

Power Supply: The amplifier plugs directly into the TYPE 1203-A or the TYPE 1204-B Unit Power Supply. It can be permanently attached with bolts supplied to form a complete assembly.

Accessories Supplied: Multipoint connector.

Tubes: One 12AX7 and two 6W6-GT are supplied.

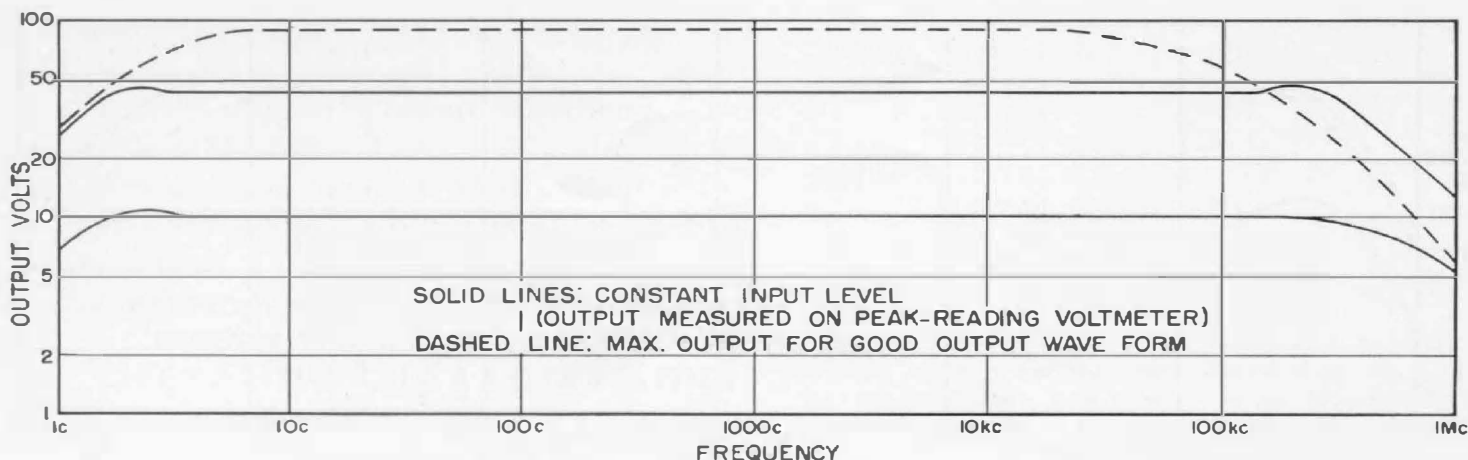

Figure 8. No-load output voltage as a function of frequency. Solid curves are for constant input voltage, dashed curves for good output waveform.

Terminals: Jack-top binding posts with standard 3/4-inch spacing.

Mounting: Black-crackle finished panel and sides. Aluminum cover finished with clear lacquer.

Dimensions: (Width) 9 7/8 x (height) 5 3/4 x (depth) 6 1/4 inches, overall.

Net Weight: 4 pounds.

Type		Code Word	Price
1206-B	Unit Amplifier	ARBOR	\$85.00
1203-A	Unit Power Supply	ALIVE	40.00

Patent applied for. Licensed under patents of the A. T. and T. Co.

"OSCILLATOR CONSIDERATIONS"

"With literally thousands of R-C band switch oscillators in use throughout the industry, we believe it is high time, particularly with the many younger engineers entering industry who may not have had experience with other types, to mention a few favorable words about the

somewhat neglected, yet definitely deserving, beat-frequency audio oscillator.

"Basic advantages of the BFO as compared with the RCO might be summarized as follows:

"1. The BFO output amplitude is constant throughout a frequency range of usually 50 cps. to 10,000 cps. and within 0.5 db to 32 kc. It is not subject to discontinuity of output level resulting from band switching as is necessary with RC types, since no band switching is necessary.

"2. Because of insufficient overlap in band switching, the investigation of important network responses occurring at RCO dial extremes becomes an inconvenient task.

"3. Thermal and warm-up stability of the BFO is far superior to the RCO. At 1,000 cps., a typical drift figure for the BFO from a cold start is in the order of 10 cps. or 1%, but is corrected with

This article is one of the best and fairest summaries that we have seen of the relative performance of beat-frequency oscillators and resistance-capacitance oscillators. It is reprinted, with permission, from *Lab Notes*, published by Gawler-Knoop Company, Sales Engineers, and was prepared by Clough-Brengle Company, one of the manufacturers whose products are distributed by Gawler-Knoop.



simple zero adjustment, so such error is diminished to essentially zero. The RCO has about the same drift with no correction control. At 1,000 cps. the BFO calibration and readability accuracy is in the order of 1% or better, while the RCO is in the order of 2% or better. After a two-hour warm-up, both the BFO and RCO have substantially stabilized. Since BFO frequency drift is a constant value, not a constant percentage, the BFO will perform even better at higher frequencies.

"4. A well-designed BFO will not exhibit frequency change with output attenuator setting changes.

"5. The rated distortion value for the BFO is usually $\frac{1}{2}$ of 1%, while the same figure for the RCO is usually 1%. These figures apply only above 100 cps., however.

"6. The BFO depends upon the stability of L rather than R . It consequently exhibits a superior calibration permanence and can take advantage of the further inherent stability resulting from a low L - to C -ratio.

"7. Much has been said of the lock-in tendencies of the BFO at low frequencies (when both high-frequency oscillators are approaching the same frequency). This problem is one of the reasons for BFO's to be more useful above 25 to 50 cps. However, let it be said that a similar problem also exists with the RCO since the tuning capacitor must operate above chassis potential, which causes it to tend to 'lock in' at power line frequency and multiples thereof.

"8. Fairness in making a comparison such as this dictates the comment that the RC circuits are ideal for low-frequency applications, generally below 50 cps., where the design problems of the BFO are extremely severe.

"Beat-frequency audio oscillators are currently manufactured commercially

by General Radio Company (who, by the way, hold the basic RC oscillator patent with 34 claims) and Clough-Brengle Co."

EDITOR'S NOTE: The General Radio Company manufactures two models of the RC-type of oscillator and four of the beat-frequency type. Each is designed for superior performance in its particular field of application.

It is possible, when the application justifies the additional expense, to improve greatly the performance of the RC oscillator. The TYPE 1301-A Low-Distortion Oscillator, for instance, affords an excellent example of how the properties of the RC-type of circuit can be used to advantage. This oscillator supplies 27 fixed frequencies between 20 and 15,000 cycles for use as test tones in the measurement of harmonic distortion. Here, by careful design of the frequency- and amplitude-controlling circuits and through the use of high-quality components, a total harmonic distortion as low as 0.1% is obtained with a frequency drift of only 0.02% per hour.

The beat-frequency oscillator has an outstanding advantage for audio-frequency testing. The frequency-control dial can be made logarithmic in frequency over a range of three decades, thus permitting the drive to be coupled directly to a recorder for the automatic recording of frequency-dependent phenomena over a range of 20 to 20,000 cycles without range switching. The RC oscillator usually requires three bands to cover this range. This logarithmic, wide-range, single-dial control is a feature of the TYPE 1304 Beat-Frequency Oscillator, which is widely used for measuring the amplitude-vs.-frequency characteristics of audio-frequency equipment.



ELECTROLYTIC CAPACITOR TESTING AT 120 CYCLES

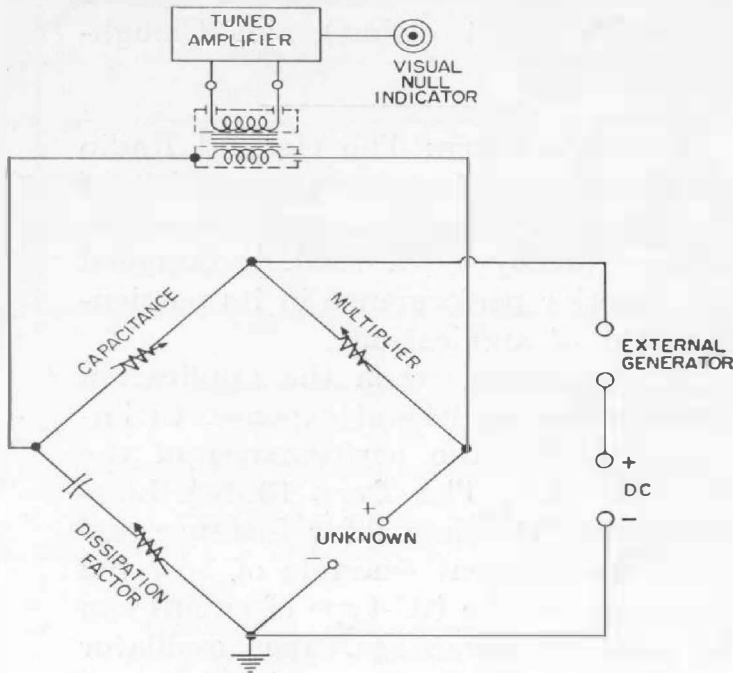

Current RETMA standards call for the measurement of electrolytic capacitors at 120 cycles. As a result, a number of our customers have requested modification of the TYPE 1611-A Capacitance Test Bridge to permit measurements at this frequency.

The inclusion of a 120-cycle source for use over the entire capacitance range of this bridge would require substantial and expensive alterations. Relatively minor and inexpensive changes, however, make possible the use of an ex-

ternal 120-cycle source for measurements with the upper four multipliers of the bridge. These multipliers cover the range from 1 μ f to 11,000 μ f, and are thus appropriate for electrolytic capacitors.

As indicated in the accompanying schematic diagram, the 120-cycle measuring voltage is applied in series with the external d-c polarizing voltage normally required for electrolytic capacitor testing. Since the d-c supply is grounded, the test voltage must be supplied through an isolation transformer, which can also serve to match the low impedance of the bridge (from a few ohms to a few thousand ohms) to the 120-cycle source.

Tuning of the detector to 120 cycles is provided, as is a jack to permit connection of a resonant circuit externally, for measurements at frequencies other than 60 cycles or 120 cycles.

The dissipation factor range is directly proportional to the test frequency; thus at 120 cycles the range of the bridge becomes 0% to 120%. The dissipation factor accuracy is $\pm (2\% \text{ of dial reading} + 0.05\% \times \frac{f}{60})$.

The modification described is designated as TYPE 1611-AS2.

Type	Code Word	Price
1611-AS2 Capacitance Test Bridge	FAVOR	\$525.00

GENERAL RADIO COMPANY

275 MASSACHUSETTS AVENUE

CAMBRIDGE 39

MASSACHUSETTS

TELEPHONE: TR owbridge 6-4400

BRANCH ENGINEERING OFFICES

NEW YORK 6, NEW YORK
90 WEST STREET
TEL.—Worth 2-5837

LOS ANGELES 38, CALIFORNIA
1000 NORTH SEWARD STREET
TEL.—HOLlywood 9-6201

CHICAGO 5, ILLINOIS
920 SOUTH MICHIGAN AVENUE
TEL.—WABash 2-3820